



masTrack

LPG Bulk Inventory Management System

The MassTrack bulk inventory management system combines the superior accuracy of Neptune mass flowmeters with real-time transaction management software to bring all product flows under your supervision. The system instantaneously tracks and balances intake against output, providing volume, mass, and density information key to reducing product loss.

MassTrack provides real-time information that has significant bottom-line impact through:

- Reduced product loss
- Timely ordering/purchasing
- Shorter billing cycles
- Faster inventory turnover
- Optimized revenue and cash flow
- Rapid payback

Easily configurable to individual bulk plants, the system can accommodate a variety of metering operations, including unloading from ships, pipelines, railcars, or motor transports, and loading to transports, bobtails, vehicle fueling, or cylinders. Neptune Coriolis mass flowmeters measure every liquid phase flow and vapor return loop. This uniquely integrated approach tightens up inventory tracking by accounting for vapor phase return flows previously not measured, particularly significant in bulk unloading or bobtail filling operations. Our proprietary, Windows-based MassTrack software is networked with the facility's



flowmeters, pumps, valves, and sensors. The system displays event data in a spreadsheet format, and provides a snapshot of the plant's volume or mass balance and total inventory position. Transaction information can be interfaced with accounting software for seamless data management. Managers can track status anytime, from anywhere, through remote monitoring and control capabilities.

User-friendly features include:

- Easy installation and configuration
- Streamlined interface
- All-operation summary screen
- Multiple language support
- Single or dual product setup
- Easily add tanks to inventory

Features and Benefits

- Coriolis mass flowmeters measure volume, mass, density, and temperature, and are highly accurate at any temperature.
- Real-time LP Gas inventory balance and total inventory volume
- Mass balances tracked and daily summaries compiled and stored, for single or multiple products
- PC-based centralized monitoring and control...anytime, anywhere reporting

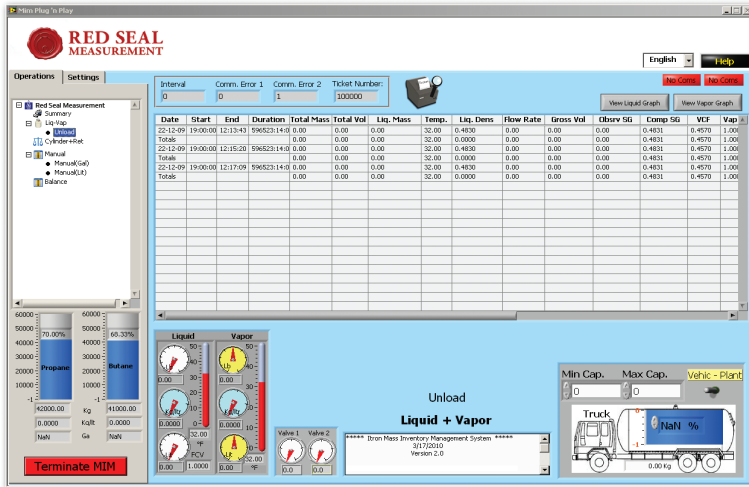

Clear, detailed report pages give information on individual operations or summarize the entire plant.



Neptune M-dot Coriolis mass flowmeters measure every fluid and vapor flow.

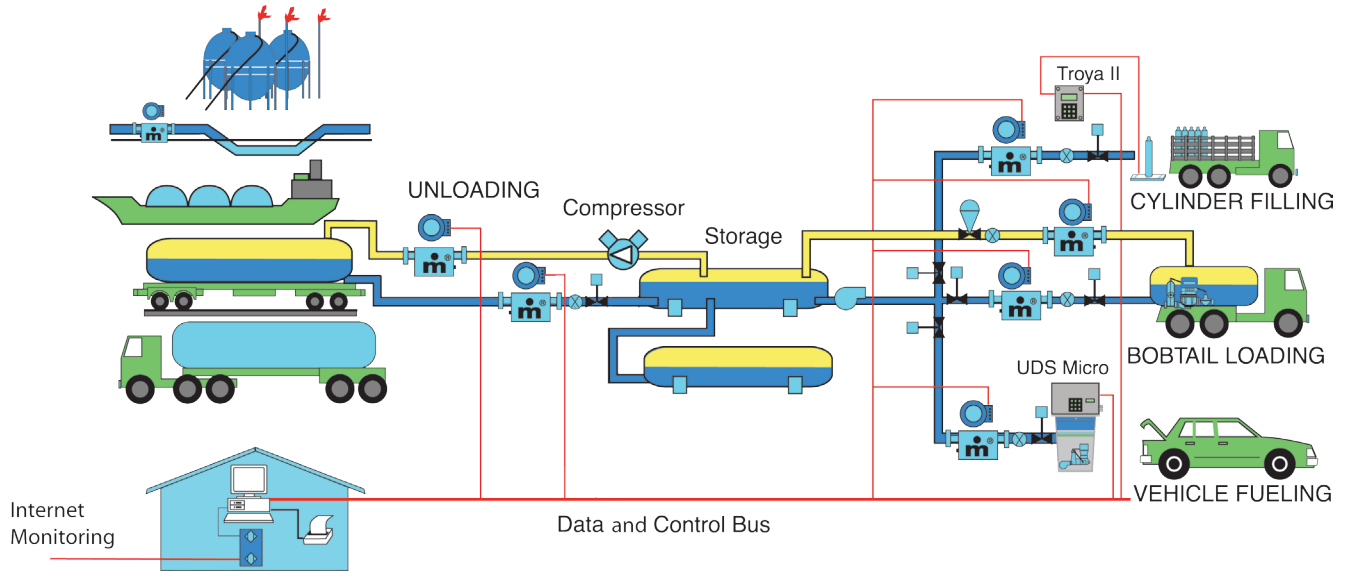

Measurement of every flow in the facility guards against product loss.

1310 Emerald Road
Greenwood, SC 29646
USA
Phone: 1.800.833.3357
Fax: 1.864.223.0341

