

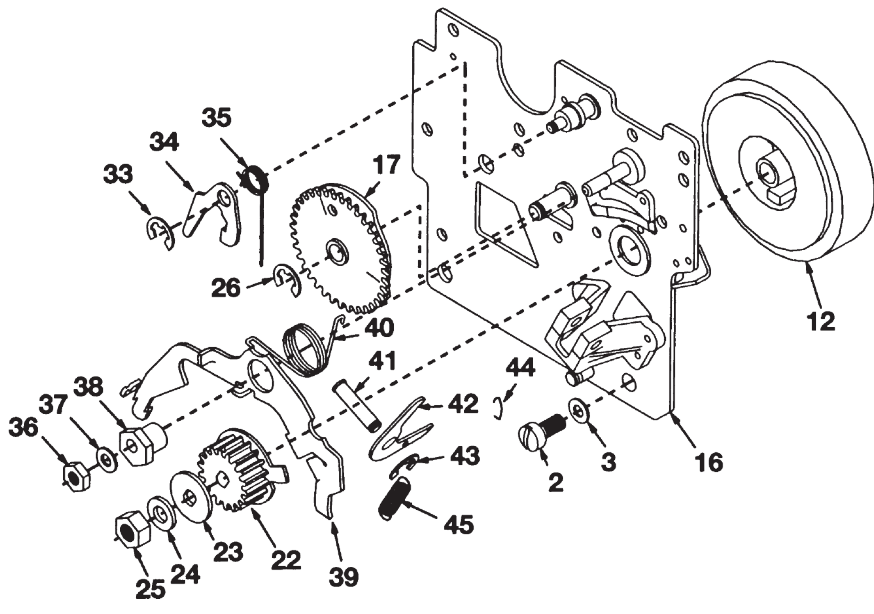

Parts List for 800 Series Registers

(For Post 5000 Serial Numbers Only)

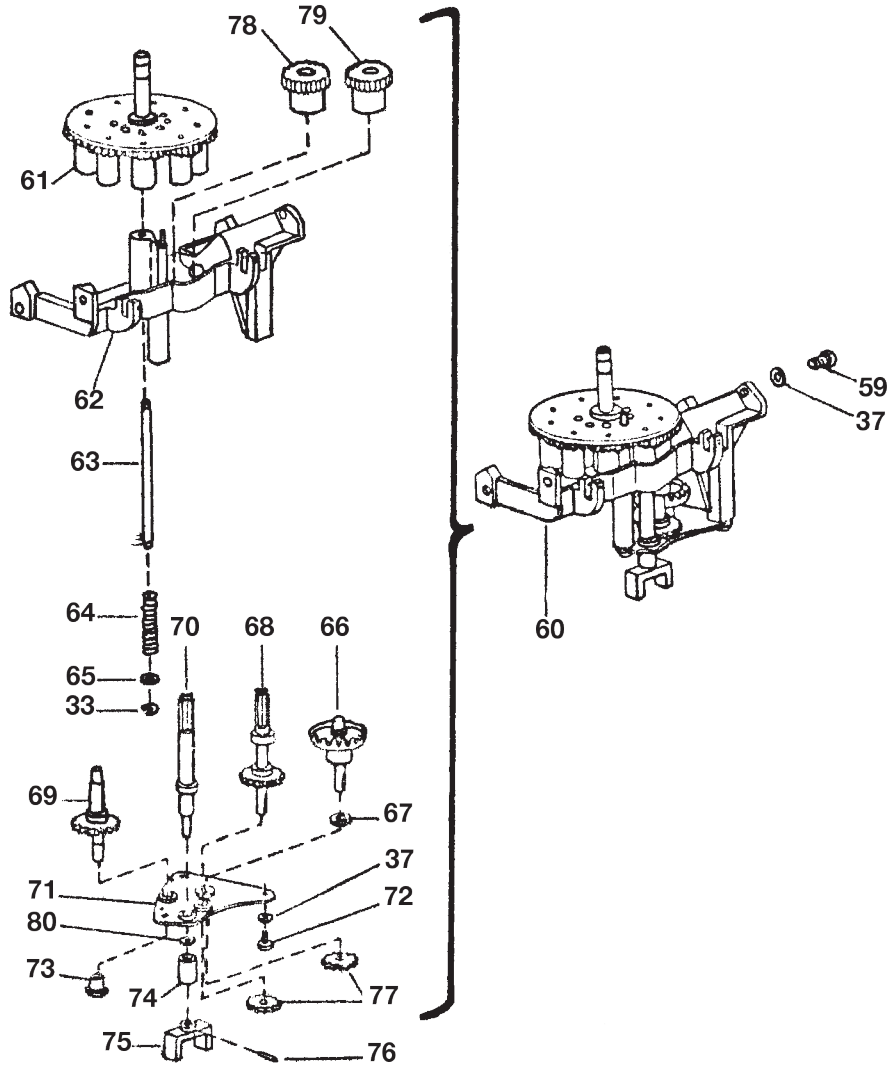



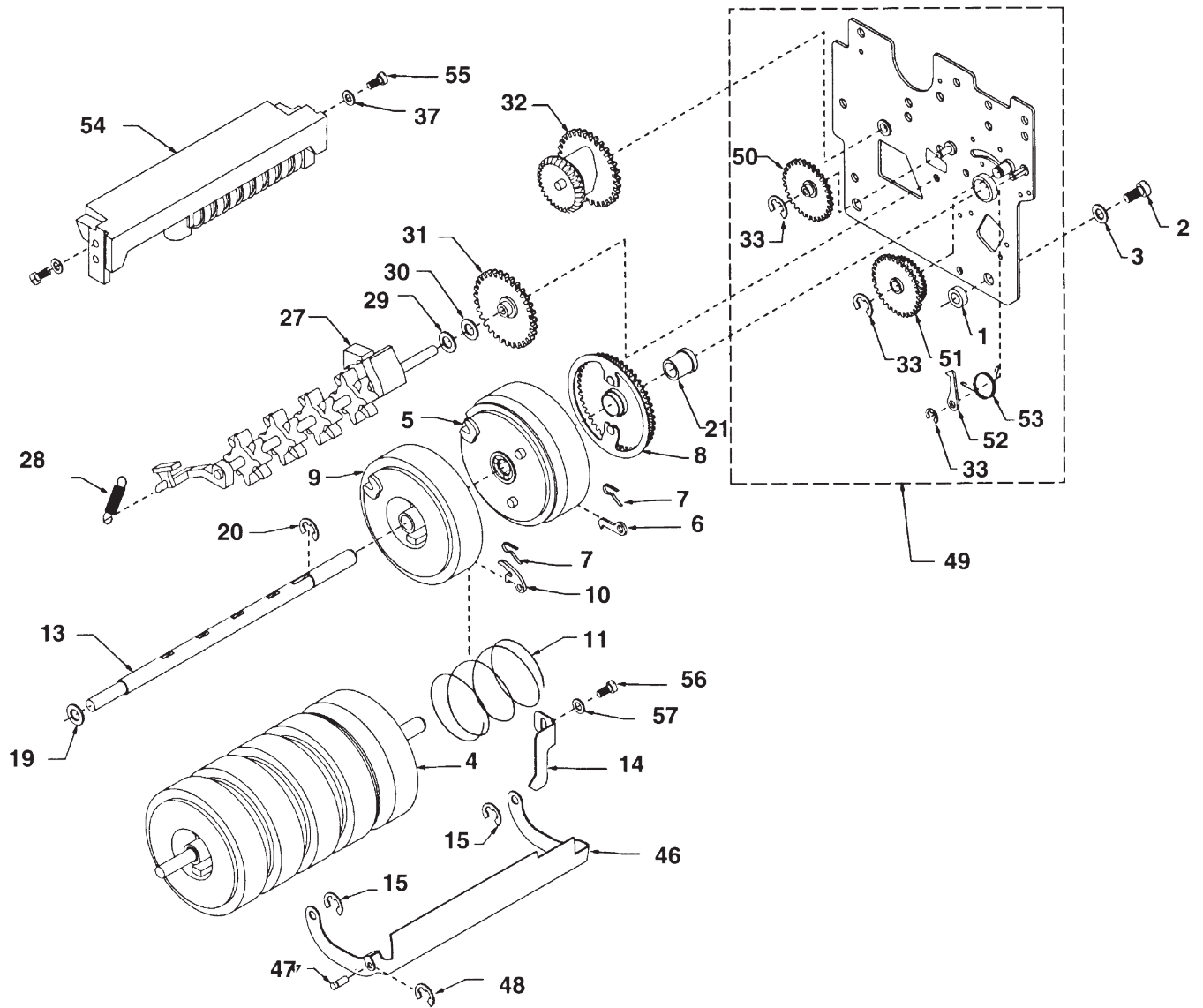

ATTACHING PARTS			
INDEX	PART NO	DESCRIPTION	USED ON
1	084285-000	Spacer, Right Side Plate	All
2	088638-002	Screw, Fil Hd St (1/4-20 x 1/2")	All
3	088721-000	Lockwasher, Internal Tooth (1/4")	All
UNIT PARTS			
4	100343-126	Wheel and Shaft Assy, Register Tenths, single cam	A, B, C, V
	100343-102	Units, single cam	D, E, F, G, S
	100343-103	Units, double cam	L
	100343-104	Units, gear drive	M, N, T
	100343-151	Units, ten subdivisions, single cam	H, J, U
	100343-153	Units with ten subdivisions, gear drive	P
	100343-176	Double digit, single cam	K, R
5	100339-126	Wheel, Register, No. 1 Tenths, single cam	A, B, C, V
	100339-102	Units, single cam	D, E, F, G, S
	100339-103	Units, double cam	L
	100339-104	Units, gear drive	M, N, T
	100339-151	Units, ten subdivisions, single cam	H, J, U
	100339-153	Units, with ten subdivisions, gear drive	P
	100339-176	Double digit, single cam	K, R
6	100311-001	Pawl (No. 1 wheel)	All
7	100568-001	Spring, Pawl	All
8	088748-000	Drive Gear and Clutch Ring Assy	All
9	100341-001	Wheel, Register (Nos. 2, 3, and 4).	All
10	100310-001	Pawl (Nos. 2, 3, 4, and 5 wheel)	All
11	100307-001	Spring, Detent	All
12	100342-001	Wheel, Register (No. 5)	All
13	100309-003	Shaft, Numeral Wheel	All
14	100483-001	Indicator, Register Wheel	All
15	088462-000	Retainer, Shutter	All
16	088514-003	Place, Left Side	All
17	088518-001	Idler Gear Assy, Reset (36-tooth)	All
19	088319-001	Washer, Plain (Special)	All
20	088320-000	Washer, Snap (Special)	All
21	088749-000	Bushing Assembly	All
22	088993-000	Resent Gear and Holdout Place Assy (18-tooth)	All
23	088499-000	Washer, Reset Gear	All
24	601051-001	Belleville Washer Spring	All
25	041981-000	Nut, Left-hand, hex, st (1/4-28)	All
26	088463-000	Retainer Ring (Waldes No. 5133-25)	All
27	088873-001	Shaft Assy, 8-tooth pinion	All
28	100472-002	Spring, Transfer	All
29	088712-000	Washer, Thrust	All
30	045779-000	Shim, Drive Gear (when needed)	All

INDEX	PART NO.	DESCRIPTION	USED ON
31	088523-000	Drive Gear Assy (28- and 31-tooth)	All
32	088432-000 088432-001	Clutch Assy, Bevel Gear (1:1 drive) Clutch Assy, Bevel Gear (1:1 drive), two-way drive	A,B,D,E,F,G,H,J,K,L,M,N,P,T,U C,R,S,V
33	088461-000	Retainer Ring (Waldes No. 5133-15)	All
34	088521-000	Latch Assy, Reset Stop Lever	All
35	088345-000	Spring, Latch	All
36	044748-000	Nut, Hex, st (10-32)	All
37	100122-007	Lockwasher, internal tooth (No. 10)	All
38	088342-000	Eccentric, Reset Stop Lever	All
39	088520-002	Lever Assy, Reset Stop	All
40	088311-001	Spring, Lever	All
41	088258-001	Pin, Shutter Crank	All
42	088522-001	Shutter Crank Assy	All
43	088462-000	Retainer Ring (Waldes No. 5133-18)	All
44	088744-000	Link Shutter	All
45	100472-003	Spring, Shutter Crank	All
46	088533-000	Shutter (with link pin)	All
47	088896-000	Pin, Connecting link	All
48	088460-000	Retaining Ring (Waldes No. 5133-12)	All
49	088946-000	Plate Assy, Right Side (1;1 drive, single zero)	All
50	088515-000	Gear Assy, 38-tooth	All
51	088516-001	Ratchet Wheel and Gear Assy (36-tooth)	All
52	088988-000	Pawl, Non-Reverse	All
53	600165-000	Spring, Pawl	All
54	088450-201 088450-203	Totalizer Assy, 10:1 drive 1:1 drive	A,B,C,V D,E,F,G,H,J,K,L,M,N,P,R,S,T,U
55	000733-001	Screw, Fil hd st (10-32 x 3/8")	All
56	041765-000	Screw, pan hd (No. 8 x 1/4")	All
57	008566-003	Washer, flat	All
59	088524-000	Screw, Special (10-32)	All
60	088423-000 089144-000 089250-000	Drive Unit Bracket Assy without reversing spindle, brass-gear shifter with reversing spindle, standard shifter standard	A,C,D,F,J,K,N,R,S,T,V,X G,L,M,P B,E,H,U
61	088430-002 089145-000	Gear Shifter Assy, with brass gears standard	A,C,D,F,J,K,N,R,S,T,V G,L,M,P
62	088949-000	Bracket with bushings	All
63	088844-000	Rod, Gear Shifter	All
64	100024-007	Spring, Gear Shifter	All
65	048785-000	Washer, Gear Shifter Spring	All
66	088172-000 089251-000	Bevel Gear, 30-tooth ("R" Spindle) Bevel Gear Assy, 30- and 23-tooth	A,C,D,F,G,J,K,L,M,N,P,R,S,T,V B,E,H,U
67	045779-000	Shim, Bevel Gear	All
68	088422-000 089255-000	Shaft Assy, Change Gear ("S" Std. Spindle) Simplified idler	A,C,D,F,G,J,K,L,M,N,P,R,S,T,V B,E,H,U
69	088420-000	Shaft Assy, Reverse Gear ("S" Rev. Spindle) - Optional	Optional - ALL See note on pg. 15
70	088428-001 089257-000	Shaft Assy, Gear Shifter Drive Standard drive	A,C,D,F,G,J,K,L,M,N,P,R,S,T,V B,E,H,U
71	088427-000	Plate Assy	All
72	000733-002	Screw, Dri-Loc (10-32 x 3/8")	All
73	-----	Obsolete Item	---
74	088429-000	Spacer, Driving Fork	All
75	088589-001	Fork, Driving	All
76	100370-004	Rollpin, 1/16 dia. x 1/2"	All
77	081230-X	Change Gear (Give number of teeth)	All
78	089259-000	Gear Assy, 30 tooth, with set screw	B,E,H,U
79	089261-000	Gear Assy, 29 tooth, with set screw	B,E,H,U
80	089263-000	Washer, Driving Fork	B,E,H,U
81	087458-001	Gear Plate	
82	008328-046	Screw, (10-32 x 3/8") Self Tapping	All

NON-PRESET UNIT AND LEVER-OPERATED PRESET UNIT

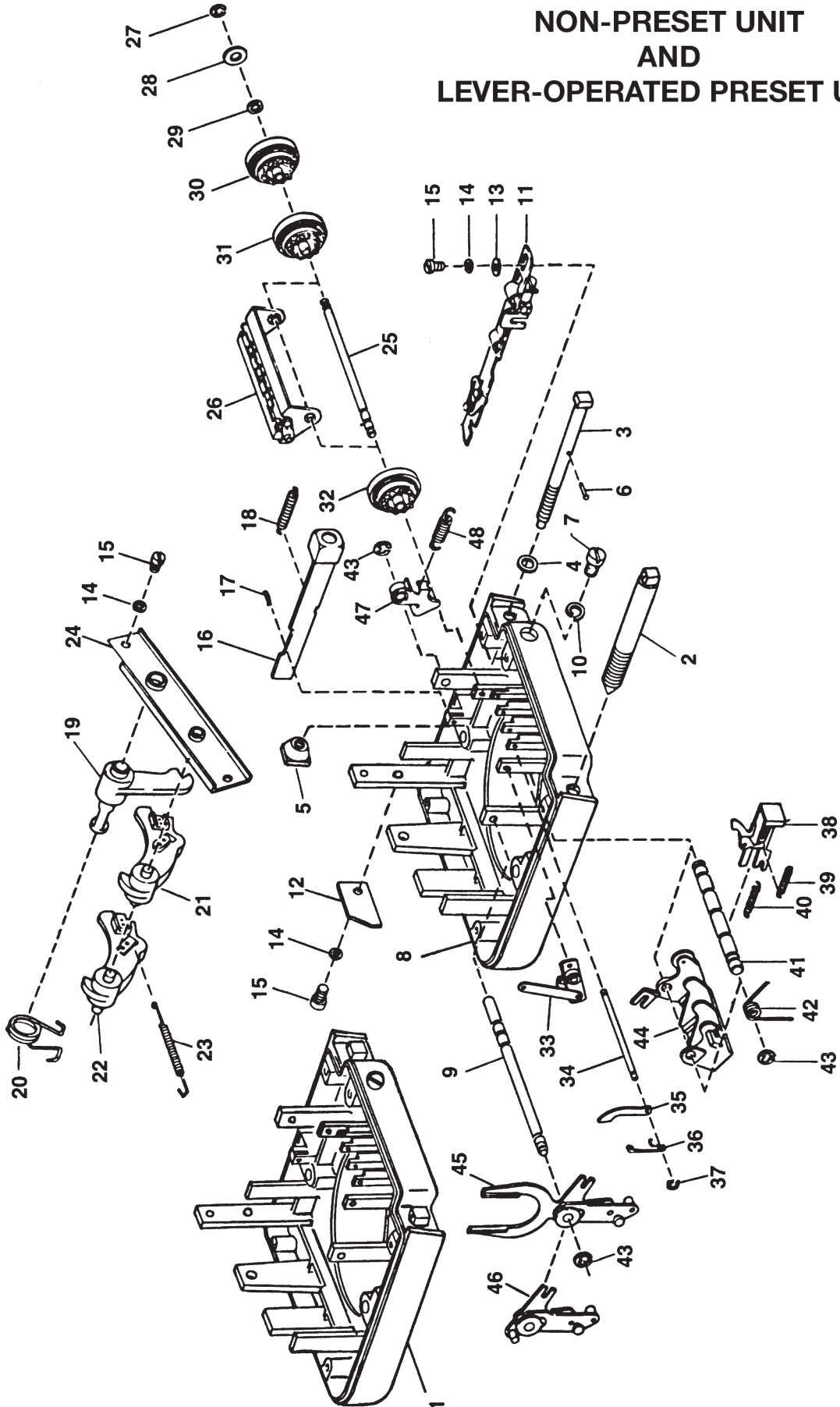

NON-PRESET UNIT

INDEX	PART NO.	DESCRIPTION	IDENTIFICATION
1	088677-100	Unit Assy, Non-Preset	A

LEVER-OPERATED PRESET UNIT

INDEX	PART NO.	DESCRIPTION	IDENTIFICATION
1	088435-401	Unit Assy, Preset	B C D E F
	088435-402	Fork Drive, 1-zero, single trip	
	088435-406	Fork Drive, 1-zero, double trip, 10-unit minimum setting	
		Fork Drive, 1-zero, double trip, 50-unit minimum setting 99,990 capacity setting)	
	088435-403	Pin Drive, 5-zero, single trip	
	088435-405	Pin Drive, 5-zero, double trip, 100-unit minimum setting	

UNIT PARTS-COMMON

INDEX	PART NO.	DESCRIPTION	USED ON
2	088183-001	Screw, Register Clamp (headless)	All
3	088184-003	Screw, Register Clamp (sq. head)	All
4	047012-001	Washer, Plain, st. stl.	All
5	088138-000	Clamp, Wedge	All
6	004050-000	Pin, Escutcheon, brass (No. 16 x 1/2")	All
7	084533-000	Screw, Fil hd brass (5/16-24 x 7/16")	All
8	088443-201	Housing Assy, Preset	B,C,D,E,F
9	088109-000	Shaft, Fork and Operating Lever	All
10	041482-000	Lockwasher, split st (5/16")	All
11	088436-002	Slide Assy, Trip	All
12	088158-000	Plate, Slide Guide	All
13	041989-000	Washer, Plain, brass (No. 10)	All
14	100122-007	Lockwasher, internal tooth (No. 10)	All
15	000733-002	Screw, Fil hd (10-32 x 3/8")	All
16	088441-000	Lever Assy, Emergency Stop	All
17	008311-001	Cotter Pin, brass (5/64" dia x 11/16")	All
18	088117-002	Spring, Lever	All
19	088154-003	Lever Trip	All
20	088984-000	Spring, Trip Lever	All
21	088156-005	Latch, Trip (single trip)	B,E,G
22	088715-002	Latch, Trip (double trip)	C,D,F,H,J
23	089138-000	Spring, Trip Latch	C,D,F,H,J
24	088157-001	Plate Mounting	All
25	088125-001	Shaft, Setting Wheel	All
26	088444-001	Bracket Assy, Feed Pawl	All
27	088462-000	Retainer Ring (Waldes No. 5133-18)	All
28	047583-000	Shim, Wheel	All
29	049987-000	Spacer, Feed Pawl Bracket	All
30	088457-501	Wheel, Preset, No. 1	B
	088456-501	Wheel, Preset, No. 1	C
	088914-501	Wheel, Preset, No. 1	E,F
	088722-501	Wheel, Preset, No. 1	D
31	088457-501	Wheel, Preset, No. 2	B,C,E,D
	088456-501	Wheel, Preset, No. 2	F
32	088457-501	Wheel, Preset, Nos. 3 & 4	All
33	088901-001	Cam Assy, Bail Mechanism	All
34	088656-000	Shaft, Stop Pawl	All
35	088654-001	Pawl, Stop	All
36	088655-002	Spring Pawl	All
37	088460-000	Retainer Ring (Waldes No. 5133-12)	All
38	088455-001	Key Assy	All
39	088118-002	Spring, Setting Pawl	All
40	088117-002	Spring, Setting Key	All
41	088144-000	Shaft, Roller Bracket	All
42	088301-001	Spring, Roller Bracket	All
43	088463-000	Retainer Ring (Waldes No. 5133-25)	All
44	088454-000	Roller Bracket Assy	All
45	088439-000	Driving Fork Assy	B,C,D
46	088645-000	Operating Lever Assy (pin type)	E,F
47	088442-000	Brake Lever Assy	All
48	088353-002	Spring, Brake Lever	All

GEAR-DRIVE PRESET UNIT

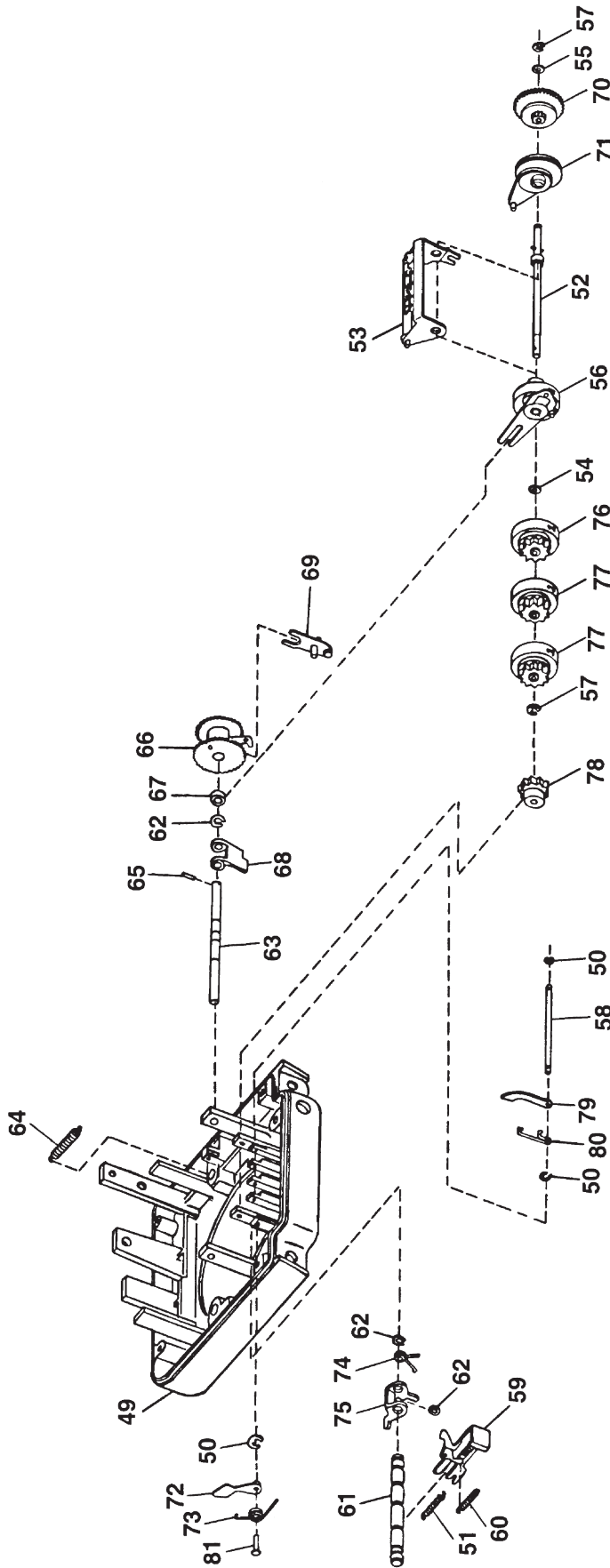

GEAR-DRIVE PRESET UNIT

PART NO.	DESCRIPTION	IDENTIFICATION
088435-501	Unit Assy, Preset	
088435-502	Gear Drive, 1-zero, single trip	G
088435-503	Gear Drive, 1-zero, double trip, 25-unit minimum setting	H
	Gear Drive, 1-zero, double trip, 50-unit minimum setting	J

UNIT PARTS

INDEX	PART NO.	DESCRIPTION	USED ON
49	088443-202	Housing Assy, Auto-Stop	G,H,J
50	088460-000	Ring, Retaining (Waldes No. 5133-12)	G,H,J
51	089072-000	Spring, No. 1 Key	G,H,J
52	089030-001	Shaft Assy, Drive	G,H,J
53	089025-000	Bracket Assy, Feed Pawl	G,H,J
54	049987-000	Spacer, Feed Pawl	G,H,J
55	046652-001	Shim, Drive Shaft	G,H,J
56	089052-501	Wheel Assy, Auto-Stop (No. 1)	G,H,J
57	088462-000	Ring, Retaining (Waldes No. 5133-18)	G,H,J
58	089008-001	Stop Pawl Shaft, Setting Wheel	G,H,J
59	089005-000	Key Assy, No. 1	G,H,J
60	089007-000	Spring, No. 1 Key Setting Pawl	G,H,J
61	089004-000	Shaft, Roller Bracket	G,H,J
62	088463-000	Ring, Retaining (Waldes No. 5133-25)	G,H,J
63	089011-000	Shaft Assy Idler Gear	G,H,J
64	089042-000	Spring, Trip Slide	G,H,J
65	100370-004	Roll Pin, 1/16" dia. x 1/2" long	G,H,J
66	089016-001	Trip Operating Lever Assy, Intermediate Gearing	G,H,J
67	089015-000	Roller, Slide	G,H,J
68	089014-000	Bail	G,H,J
69	089023-000	Lever Assy, Trip	G,H,J
70	089067-001	Ratchet & Gear Assy, Drive	G,H,J
71	089059-001	Cam Assy, Trip	G,H,J
72	089009-000	Pawl, Star Wheel	G,H,J
73	088073-000	Spring, Star Wheel	G,H,J
74	089036-000	Spring, Bail Bracket	G,H,J
75	089037-000	Bracket Assy, Bail	G,H,J
76	088457-501	Wheel, Preset, No. 2	G
	088955-501	Wheel, Preset, No. 2	H
	088722-501	Wheel, Preset, No. 2	J
77	088457-501	Wheel, Preset, No.s 3 & 4	G,H,J
78	089190-001	Star Wheel Assy	G,H,J
79	088654-001	Pawl, Stop	G,H,J
80	088655-002	Spring Pawl	G,H,J
81	089192-001	Pin	G,H,J

Unit parts not listed are same as for Lever-Operated Preset Unit, pages 6 and 7.

NON-PRINT UNIT AND PRINT UNIT

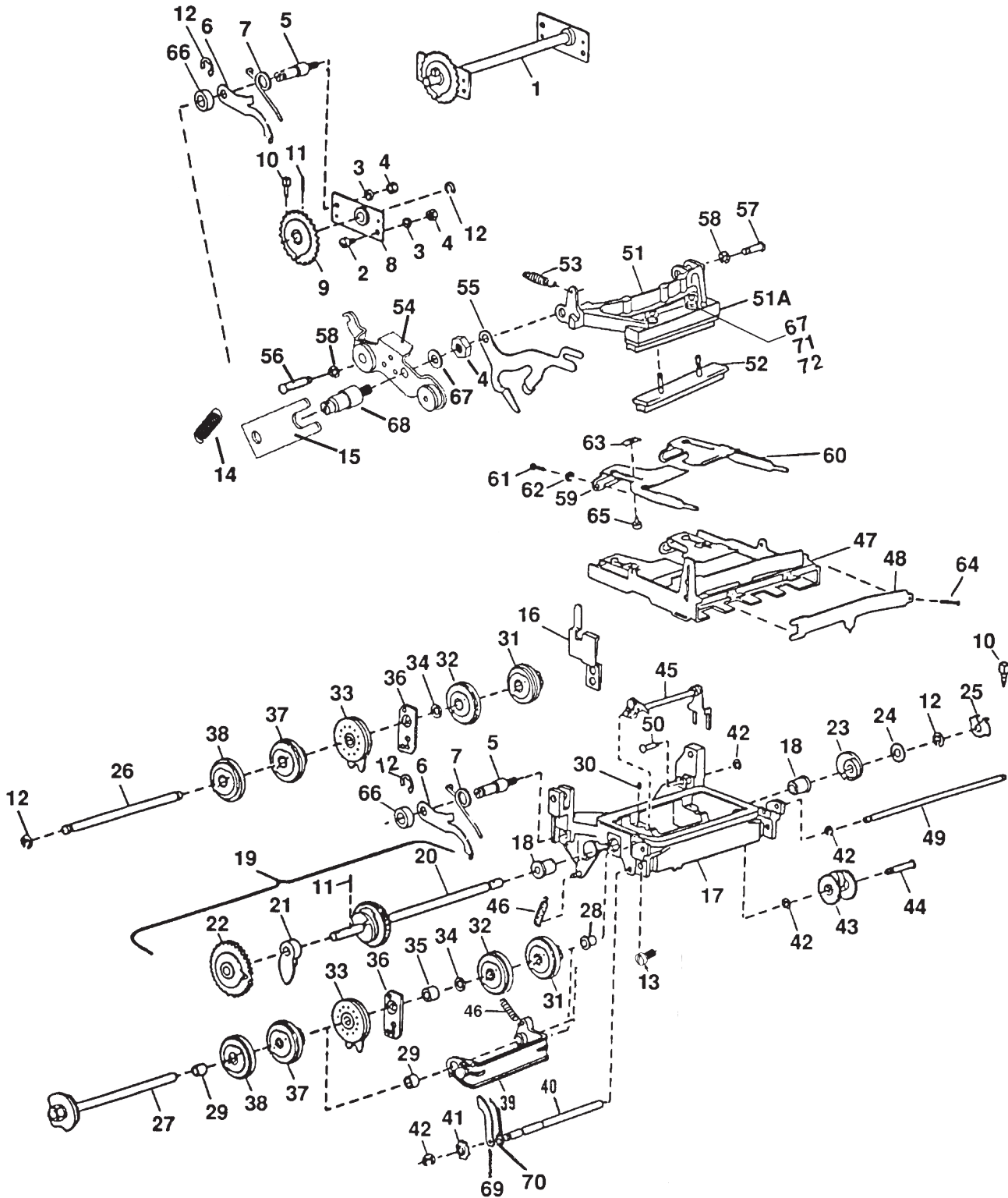

NON-PRINT UNIT

DESCRIPTION	IDENTIFICATION
Non-Print Unit	A

ATTACHING PARTS

INDEX	PART NO.	DESCRIPTION	USED ON
1	088788-002	Reset Shaft Assy	A
2	000733-001	Screw, Fil hd st (10-32 x 3/8")	A
3	100122-007	Lockwasher, internal tooth (No. 10)	A
4	044748-000	Nut, hex st (10-32)	A
5	600096-000	Stud, Reset Arm Return Knob	A
6	088500-002	Arm, Reset Knob Return	A
7	088502-001	Spring, Reset Knob Return Arm	A

UNIT PARTS

8	See Note	Bracket, Reset Shaft (Note: Must Order Part #88788-002)	A
9	088629-001	Reset Gear Assy, 36-tooth	A
10	088316-003	Pin, Reset Knob	A
11	100370-040	Pin	A
12	008579-026	Retainer Ring (Waldes No. 5133-25)	A

PRINTER UNIT

PART NO.	DESCRIPTION	IDENTIFICATION
088635-000 088635-001 088635-022	Print Unit Assy, Zero Start Face up, tenths units units, fixed 'l'	B F K
088635-050 088635-056 088635-077	Face down, tenths units units, fixed 'l'	D H L
088675-050 088675-000 088675-029 088675-001 088675-027 088675-028	Printer Unit Assy, Totalizer Face up, tenths Face down, tenths tenths, two-way drive units units, fixed 'o' units, fixed 'l'	E C N G J M

ATTACHING PARTS

INDEX	PART NO.	DESCRIPTION	USED ON
13	088524-002	Screw, Special (10-32 x 3/8") Dri-Lock	All
14	103008-001	Spring, Hammer	All
15	103006-001	Hammer Lift Stop	All
16	088313-003	Guide, Ticket Punch Lever	All

UNIT PARTS

17	088626-002	Frame Assy, Print	All
18	088291-001	Shaft Assy Complete, Reset	All
19	100164-003	Shaft Assy, Reset	All
20	088628-002	Cam, hammer Lift	All
21	088260-000	Reset Gear Assy, 36-tooth	All
22	088629-001		All
23	088297-000	Cam, Ticket Slide Actuating	All
24	088723-000	Shim, Reset Shaft (when needed)	All
25	088747-001	Washer, Interlock	All
26	088498-001	Shaft, Wheel, Totalizer type	C,E,G,J,M,N
27	088617-002	Shaft Assy, Wheel, zero-start type	B,D,F,H,K,L
28	008344-130	Bushing, Flange, Print Wheel Shaft	All
29	088289-001	Bushing, Print Wheel Shaft	All
30	008538-023	Setscrew, Allen, hex socket, cone-pt (5-40 x 3/16")	All

INDEX	PART NO.	DESCRIPTION	USED ON
31	088660-003 088663-003 100173-002 088601-003 088580-003 100174-002 088794-001	Print Wheel No. 1 Zero start, face, up tenths face up, units face up, units, fixed 'l' face down, tenths face down, units face down, units, fixed 'l' face up, units	B F K D H L R
	088780-001 088550-001 088581-001 100172-001 100172-002	Totalizer, face up, tenths face down, tenths face down, units face down, units, fixed 'o' face down, units, fixed 'l'	E C G J M
32	100739-001 100740-001 100978-001 100979-001	Print Wheel, Intermediate Zero start, face up face down Totalizer, face up face down	B,F,K D,H,L E C,G,J,M,N
33	088669-000 088607-000 008571-005	Print Wheel, Identifying Face up Face down Spacer	B,E,F,K C,D,G,H,J,L,M,N All
35 36	088698-000 088891-000	Spacer, Print Wheel Plate Assy, Adjusting	B,D,F,H,K,L All
37	101076-001 101076-002	Serial Print Wheel, No. 1 Face up Face down	B,E,F,K C,D,G,H,J,L,M,N
38	100978-001 100979-001	Serial Print Wheel, Nos. 2 & 3 Face up Face down	B,E,F,K C,D,G,H,J,L,M,N
39 40 41 42	088616-003 088616-004 088339-000 088600-000 088461-000	Yoke Assy, Serial No. Device Yoke Assy, Serial No. Device, Two-way Drive Shaft, 10-tooth pinion Pinion, 10-tooth Retainer Ring (Waldes No. 5133-15)	A,B,C,D,E,F,G,H,J,K,L,M, N All All All
43 44 45 46	088618-000 088317-000 088619-000 088273-000	Cam Assy, Serial No. Device Shaft Cam Shaft Assy, Serial No. Device Spring, Full Stroke	All All All All
47 48 49 50	088623-000 088294-000 088300-000 088299-001	Slide Assy, Ticket Punch, Ticket Shaft, Slide Retaining Pin, Slide Retaining	All All All All
51 51A 52 53	088624-009 088248-002 088249-009 088255-000	Hammer Assy Hammer Cushion Spring, Hammer Retaining Spring	All All All All
54 55 56 57 58	088637-003 088293-002 088259-001 088258-001 088462-000	Lever Assy, Hammer Lift Lever, Ticket Punch Actuating Pin, Hammer (long) Pin, Hammer (short) Retainer Ring (Waldes No. 5133-18)	All All All All All
59 60 61 62 63 64 65 66 67 68	088295-001 088296-001 046032-000 008564-030 088546-000 044585-000 088672-000 084285-000 041211-000 103007-001	Guide - Ticket, left side Guide - Ticket, right side Screw - Rd. hd, 8-32 x 1/4-in., steel Washer - Lock, internal tooth, steel (for No. 8 machine screw) Fastener - Speed nut (Tinnerman part No. C12003-017-1) Pin - Cotter, 1/16 x 3/8-in., brass Stop- Ticket Spacer, right side plate Washer, Lock - Internal #10 Hammer Lift Lever Stud	All All All All B,D,F,H,K,L All B,D,F,H,K,L All All All All
69 70 71 72	088979-000 088980-000 049987-000 044748-000	Pawl Retainer, Serial Print Wheel Spring, Pawl Retaining Washer Nut	All All All All

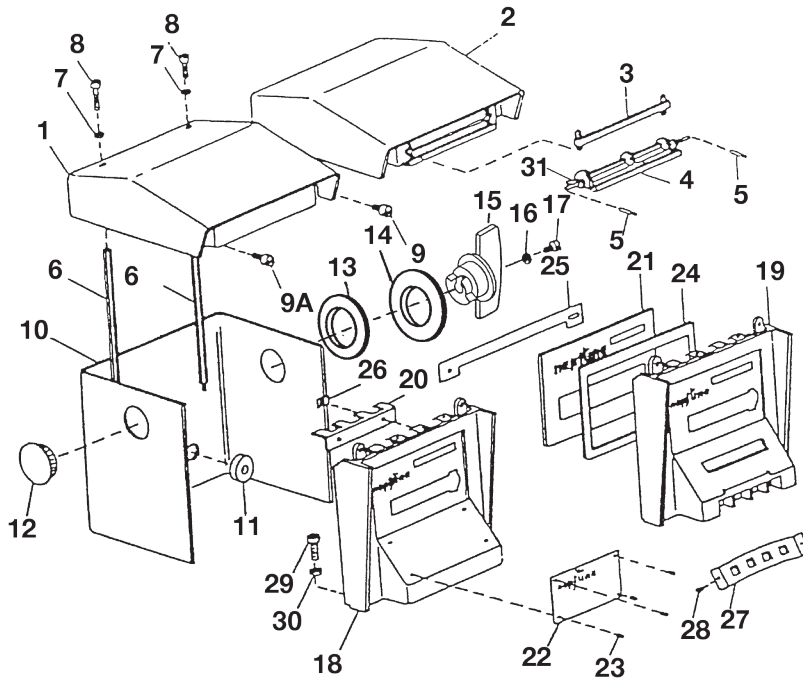

HOUSING

INDEX	PART NO.	DESCRIPTION	USED ON
1	088544-005	Cover Assy, Non-Printer (Give Model & Code)	A,B
2	088894-101	Cover Assy, Printer	C,D
3	088691-000	Support, Ticket	C,D
4	101316-001	Cover, Assy, Ticket Slot	C,D
5	100370-003	Pin, Ticket Slot Cover	C,D
6	088331-000	Post, Cover Support	All
7	041211-000	Lockwasher, internal tooth (No. 10)	All
8	089073-000	Screw, Fil hd st (10-32 x 1 1/4")	All
9A	009287-016	Screw, Lg. Fil hd (10-32 x 1/2")	All
9	009287-003	Screw, Special (10-32), Drilled	All
10	088322-020	Housing, Register	All
11	088641-000	Washer, Housing Seal	All
12	100745-001	Plug, Cap	All
13	088318-003	Washer, Reset Knob and Cover	All
14	088711-003	Retainer, Washer	All
15	088315-002	Knob, Reset	All
16	041982-002	Lockwasher, Split (No. 8)	All
17	008326-002	Screw, Fil hd st (8-32 x 3/8")	All
18	088542-20X	Housing Assy, Front, Non-Preset (Specify units of measure.)	A,C
19	088541-20X	Housing Assy, Front, Preset (Specify units of measure, register model and code).	B,D
20	088332-001	Guide, Ticket	All
21	088960-30X	Mask, Register Wheel (Specify units of measure.)	All
22	101113-001	Nameplate, Direct Reading Register	A
	101114-001	Nameplate, Preset Register	B
	101115-001	Nameplate, Printer Register	C
	101116-001	Nameplate, Printer-Preset Register	D
23	041792-000	Drive Screw	All
24	088826-000	Gasket, Register Wheel Mask	All
25	101084-001	Bar, Stiffener	All
26	100046-001	Fastener (Tinnerman No. C19275-17-1)	All
27	1002470	Mask, Preset Wheel, without "0"	B,D
	1002530	Mask, Preset Wheel, with "0"	B,D
28	088912-000	Screw, rd hd (Parker Kalon Type Z, No. 4 x 3/16")	B,D
29	088640-000	Screw, Allen, hex socket, st, flat-pt (1/4-20 x 5/8")	All
30	088721-000	Lockwasher, internal tooth (1/4")	All
31	088334-000	Ticket slot cover spring	C,D

800 SERIES REGISTER UNIT IDENTIFICATION

To determine the internal components of the register, use the following index showing register Model and Code followed by specifications and a four letter key. The four letter key represents the Unit identification of the major units that go into making up a complete register.

The basic nomenclature for each key letter of the Unit identification is described on the following page.

MODEL AND CODE	REGISTER PART NO. COMPLETE	UNITS	NO. 1 REG. WHEEL	SHIFTER	PRESET					PRINT		REMARKS	IDENTIFICATION			
					TYPE	TRIP	MIN. SET	INCR.	FIX'O	TYPE	FIXED		TYPE	PRE-SET	PRINT	HSG.
831-0	880018-000	GAL	TENTHS	WGP									A	A	A	A
831-OC	880010-016	GAL	TENTHS	STD									A	A	A	A
831-2	880010-003	GAL	TENTHS	WGP							1		C	A	A	A
831-9	880010-023	DEK	TENTHS	WGP									A	A	A	A
831-10	880010-024	LIT	TENTHS	WGP									A	A	A	A
831-11	880010-025	GAL	TENTHS	STD									A	A	A	A
831-12	880010-026	GAL	TENTHS	STD							1		V	A	A	A
832-0	880020-000	GAL	TENTHS	WGP	FD	ST							A	B	A	B
832-1	880020-001	GAL	TENTHS	WGP	FD	DT	10	1					A	C	A	B
832-14	880020-025	GAL	TENTHS	WGP	GD	ST		1					A	G	A	B
832-17	880020-035	DEK	TENTHS	WGP	FD	ST		1					A	B	A	B
832-18	880020-036	DEK	TENTHS	WGP	FD	DT	10	1					A	C	A	B
832-19	880020-037	GAL	TENTHS	STD	FD	ST		1					A	B	A	B
832-20	880020-038	GAL	TENTHS	STD	FD	DT	10	1					A	C	A	B
833-0	880030-000	GAL	TENTHS	STD								ZU	A	A	B	C
833-1	880030-001	GAL	TENTHS	STD								TD	A	A	C	C
833-2	880030-200	GAL	TENTHS	STD								ZD	A	A	D	C
833-3	880030-009	GAL	TENTHS	STD								TU	A	A	E	C
833-22	880030-045	GAL	TENTHS	STD								TD	V	A	N	C
833-23	880030-046	DEK	TENTHS	STD							1	ZU	A	A	B	C
834-0	880040-000	GAL	TENTHS	STD	FD	ST		1					A	B	B	D
834-1	880040-001	GAL	TENTHS	STD	FD	DT	10	1					A	C	B	D
834-2	880040-002	GAL	TENTHS	STD	FD	ST		1					A	B	C	D
834-3	880040-003	GAL	TENTHS	STD	FD	DT	10	1					A	C	C	D
834-4	880040-200	GAL	TENTHS	STD	FD	ST		1					A	B	D	D
834-5	880040-201	GAL	TENTHS	STD	FD	DT	10	1					A	C	D	D
834-5C	880040-202	GAL	TENTHS	STD	FD	DT	10	1					B	C	D	D
834-34	880040-061	DEK	TENTHS	STD	FD	ST		1					A	B	B	D
834-35	880040-062	DEK	TENTHS	STD	FD	DT	10	1					A	C	B	D
841-L	880110-100	GAL	UNITS	WGP									D	A	A	A
841-LC	880110-120	GAL	UNITS	STD									E	A	A	A
841-L1	880110-102	LIT	UNITS	WGP									F	A	A	A
S841-L2	880110-128	LBS	UNITS	WGP									G	A	A	A
841-L6C	880110-150	LIT	UNITS	STD									E	A	A	A
841-L10	880110-118	GAL	UNITS	WGP									G	A	A	A
S841-L11	880110-129	KILOS	UNITS	WGP							1		G	A	A	A
841-L12C	880110-155	DEK	1/10SD	STD									H	A	A	A
841-L15	880110-132	LIT	1/10SD	WGP									J	A	A	A
841-L15C	880110-148	LIT	1/10SD	STD									H	A	A	A
841-L19	880110-156	LIT	00	WGP									K	A	A	A
841-L24	880110-162	DEK	UNITS	WGP									F	A	A	A
841-L25	880110-163	LIT	1/10SD	WGP									W	A	A	A
841-L26	880110-164	GAL	UNITS	STD									D	A	A	A
841-L27	880110-165	GAL	UNITS	STD									F	A	A	A
841-L28	880110-166	LIT	1/10SD	STD							1		J	A	A	A
841-L29	880110-167	LIT	UNITS	STD									F	A	A	A
842-L	880120-100	GAL	UNITS	WGP	FD	ST		10	X				D	B	A	B
842-L1	880120-102	LIT	UNITS	WGP	FD	ST		10	X				F	B	A	B
842-L1C	880120-228	LIT	UNITS	STD	FD	ST		10	X				E	B	A	B
842-L2	880120-161	LBS	UNITS	WGP	PD	ST		5					L	E	A	B
842-L3	880120-125	LIT	UNITS	WGP	FD	DT	100	10	X				F	C	A	B
842-L8	880120-163	LBS	UNITS	WGP	PD	DT	100	5					L	F	A	B
842-L9	880120-117	GAL	UNITS	WGP	FD	DT	50	10	X				D	D	A	B
S842-L12	880120-165	KILOS	UNITS	WGP	PD	DT	100	5					L	F	A	B
842-L14	880120-167	LBS	UNITS	WGP	FD	DT	100	10	X				G	C	A	B
842-L15	880120-168	LBS	UNITS	WGP	GD	ST		1					M	G	A	B
842-L23	880120-190	LIT	UNITS	WGP	GD	ST		1					N	G	A	B
S842-L16	880120-162	KILOS	UNITS	WGP	PD	ST		5					L	E	A	B
842-L27	880120-153	LIT	UNITS	WGP	FD	DT	50	10	X				F	D	A	B
842-L28C	880120-205	GAL	UNITS	STD	FD	DT	100	10	X				E	C	A	B
S842-L32	880120-187	LBS	1/10SD	WGP	GD	DT	50	1					P	J	A	B
842-L33	880120-191	LIT	1/10SD	WGP	FD	ST		10	X				J	B	A	B
842-L33C	880120-221	LIT	1/10SD	STD	FD	ST		10	X				H	B	A	B
842-L37	880120-199	LIT	1/10SD	WGP	FD	DT	50	10	X				J	D	A	B
842-L37C	880120-222	LIT	1/10SD	STD	FD	DT	50	10	X				U	D	A	B
842-L44	880120-212	LIT	00	WGP	GD	DT	25	1					K	H	A	B
S842-L45	880120-216	GAL	1/10SD	WGP	GD	DT	25	1					P	H	A	B
842-L46	880120-217	DEK	UNITS	WGP	FD	DT	50	10	X				F	D	A	B
S842-L47	880120-218	KILOS	UNITS	WGP	GD	ST		1					M	G	A	B
S842-L48	880120-219	KILOS	1/10SD	WGP	GD	DT	25	1					P	H	A	B
842-L49	880120-220	LIT	1/10SD	WGP	GD	DT	25	1					H	H	A	B
842-L50	880120-223	GAL	UNITS	STD	FD	ST		10	X				F	B	A	B
842-L51	880120-224	GAL	UNITS	STD	FD	DT	50	10	X				X	A	A	B
842-L52	880120-225	LIT	UNITS	STD	FD	ST		10	X				F	D	A	B
842-L53	880120-226	LIT	1/10SD	STD	FD	DT	50	10	X				J	D	A	B
842-L54	880120-227	LIT	1/10SD	STD	FD	ST		10	X				J	B	A	B
842-L55	880120-229	LBS	UNITS	STD	FD	DT	100	10	X				F	L	A	B

MODEL AND CODE	REGISTER PART NO. COMPLETE	UNITS	NO. 1 REG. WHEEL	SHIFTER	PRESET					PRINT		REMARKS	IDENTIFICATION			
					TYPE	TRIP	MIN. SET	INCR.	FIXO	TYPE	FIXED		TYPE	PRESET	PRINT	HSG.
843-L	880130-100	GAL	UNITS	STD						ZU			D	A	F	C
843-LC	880130-143	GAL	UNITS	STD						ZU			E	A	F	C
843-L1	880130-105	LIT	UNITS	STD						ZU			F	A	F	C
843-L2	880130-103	GAL	UNITS	STD						TD			D	A	G	C
843-L2C	880130-135	GAL	UNITS	STD						TD			E	A	G	C
843-L7	880130-112	GAL	UNITS	STD						ZD			D	A	G	C
843-L10	880130-130	LIT	UNITS	STD						TD			F	A	H	C
843-L15	880130-158	LIT	1/10SD	STD						ZU			J	A	F	C
843-L21	880130-175	LIT	UNITS	STD						ZD			F	A	H	C
843-L22	880130-179	LIT	1/10SD	STD						ZD			J	A	H	C
843-L26	880130-198	LIT	00	STD						TD	O		K	A	J	C
843-L29	880130-206	LIT	1/10SD	STD						ZU	1		J	A	K	C
843-L29C	880130-219	LIT	1/10SD	STD						TD			H	A	G	C
843-L32	880130-213	LIT	1/10SD	STD						ZD	1		J	A	L	C
843-L32C	880130-220	LIT	1/10SD	STD						ZD	1		H	A	L	C
843-L33	880130-214	LIT	1/10SD	STD						TD	1		J	A	M	C
843-L33C	800130-221	LIT	1/10SD	STD						TD	1		H	A	M	C
843-L34	880130-215	KILOS	1/10SD	STD						ZU			J	A	F	C
843-L35	880130-216	DEK	UNITS	STD						TD			F	A	G	C
843-L37	880130-218	LIT	UNITS	STD						TD		1	S	A	G	C
843-L39	880130-223	LIT	1/10SD	STD						ZU			W	A	F	C
843-L40	880130-224	DEK	UNITS	STD						TU			F	A	E	C
844-L1	880140-103	LIT	UNITS	STD	FD	ST		10	X	ZU			F	B	F	D
844-L2	880140-102	GAL	UNITS	STD	FD	ST		10	X	TD			D	B	G	D
844-L6	880140-111	GAL	UNITS	STD	GD	DT	50	1		TD			T	J	G	D
844-L30	880140-153	GAL	UNITS	STD	FD	DT	50	10	X	TD			D	D	G	D
844-L30C	880140-215	GAL	UNITS	STD	FD	DT	50	10	X	TD			E	D	G	D
844-L33	880140-205	LIT	UNITS	STD	GD	ST		10	X	ZU			T	G	H	D
844-L36	880140-168	LIT	1/10SD	STD	FD	ST		10	X	ZU			J	B	F	D
844-L41	880140-214	GAL	UNITS	STD	FD	DT	50	10	X	ZU			F	D	F	D
844-L43	880140-217	GAL	UNITS	STD	FD	DT	50	10	X	TD			F	D	G	D
844-L50	880140-238	LIT	1/10SD	STD	FD	ST		10	X	ZD			J	B	H	D
844-L51	880140-299	LIT	1/10SD	STD	FD	DT	50	10	X	ZD			J	D	H	D
844-L55	880140-247	LIT	1/10SD	STD	FD	DT	50	10	X	ZU			J	D	F	D
844-L69	880140-277	LIT	1/10SD	STD	FD	DT	50	10	X	ZD	1		J	D	L	D
844-L69C	880140-292	LIT	1/10SD	STD	FD	DT	50	10	X	ZD	1		U	D	L	D
844-L73	880140-278	LIT	1/10SD	STD	FD	DT	50	10	X	TD	1		J	D	M	D
844-L73C	880140-295	LIT	1/10SD	STD	FD	DT	50	10	X	TD	1		U	D	M	D
844-L75	880140-280	LIT	1/10SD	STD	FD	DT	50	10	X	ZU	1		J	D	K	D
844-L75C	880140-294	LIT	1/10SD	STD	FD	DT	50	10	X	ZU	1		U	D	K	D
844-L82	880140-290	LIT	1/10SD	STD	FD	ST		10	X	ZD	1		J	B	L	D
844-L82C	880140-296	DEK	1/10SD	STD	FD	ST		10	X	ZD	1		H	B	L	D
844-L83	880140-291	GAL	UNITS	STD	FD	DT	50	10	X	TD			F	D	G	D
844-L84	880140-293	LIT	UNITS	STD	GD	ST		10	X	ZU			F	B	F	D
844-L85	880140-297	LIT	1/10SD	STD	GD	DT	25	1		ZD			T	H	H	D
844-L86	880140-298	LIT	UNITS	STD	GD	DT	50	1		ZU			T	J	E	D
844-L88	880140-301		1/10SD	WGP	GD	ST		1		ZD			X	G	H	D

Remarks
1-Two-Way Drive

KEY TO CODED TERMS (Page 14)

1/10 SD = Units w/tenths sub divisions No. 1 register wheel
 00 = 100 Units No. 1 register wheel
 STD = Standard .15% increment gear shifter
 WGP = With gear place
 FD = Fork-drive preset
 GD = Gear-drive preset
 PD = Pin-driver preset

ST = Single trip preset
 DT = Double trip preset
 ZU = Zero start/face up printer
 ZD = Zero start/face down printer
 TU = Totalizer/face up printer
 TD = Totalizer/face down printer

DESCRIPTION OF MAJOR UNITS OF 800 SERIES REGISTERS AS INDICATED BY VARIOUS KEY LETTERS

To determine the features of a given 800 Series Register:

1. Note the Model and Code Number as stamped on the front place
2. Using the " Unit Identification" (page 14) locate the key letter for each major unit.
3. Using the unit key letters, find the features described opposite the corresponding letter in the table below.

Register Unit (1st Key Letter)¹

- A - Tenths, single cam.
- B - Tenths, single cam.
- C - Tenths, two-way drive, single cam.
- D - Units, single cam.
- E - Units, single cam.
- F - Units, single cam.
- G - Units, standard shifter, single cam.
- H - Units, with ten subdivisions, standard drive brackets, single cam.
- J - Units, with ten subdivisions, single cam.
- K - Double digit, single cam.
- L - Units, standard shifter, double cam.
- M - Units, standard shifter, gear drive.
- N - Units, gear drive.
- P - Units, with ten subdivisions, silver top, single trip, gear drive.
- R - Double digit, two-way drive, single cam.
- S - Units, two-way drive, single cam.
- T - Units, gear drive.
- U - Units, with ten subdivisions, double cam.
- V - Tenths, two-way drive, single cam.
- W - Units, with ten subdivisions, without gear shifter, with reversing spindle.
- X - Units, with ten subdivisions, gear drive.
- Y - Double digit.

¹The reversing spindle can be installed on all registers. Specify the addition of Part No. 88420-000 when ordering a register.

Preset Unit (2nd Key Letter)

- | | |
|--|---|
| <ul style="list-style-type: none"> A - Non Preset B - Single Trip, Fork Drive C - Double Trip, Fork Drive, 10 Unit Minimum Setting D - Double Trip, Fork Drive, 50 Unit Minimum Setting E - Single Trip, Pin Drive F - Double Trip, Pin Drive 100 Unit Minimum Setting | <ul style="list-style-type: none"> G - Single Trip, Gear Drive H - Double Trip, Gear Drive, 25 Unit Minimum Setting J - Double Trip, Gear Drive, 50 Unit Minimum Setting K - Double Trip, 25 Unit Minimum Setting L - Double Trip 100 Unit Minimum Setting |
|--|---|

Print Unit (3rd Key Letter)

- | | |
|---|---|
| <ul style="list-style-type: none"> A - Non Print B - Zero Start Printer, Face Up, Tenths C - Totalizer Printer, Face Down, Tenths D - Zero Start Printer, Face Down, Tenths E - Totalizer Printer, Face Up, Units G - Totalizer Printer, Face Down, Units H - Zero Start Printer, Face Down, Units | <ul style="list-style-type: none"> J - Totalizer Printer, Face Down, Units, Fixed K - Zero Start Printer, Face Up, Units, Fixed L - Zero Start Printer, Face Down, Units, Fixed M - Totalizer Printer, Face Down, Units, Fixed N - Totalizer Printer, Face Down, Tenths, Two-Way Drive P - Zero Start Printer, Face Down, Units, Fixed R - Totalizer Printer, Face Up, Units |
|---|---|

Housing (4th Key Letter)

- | | |
|--|--|
| <ul style="list-style-type: none"> A - Non Preset, Non Printer B - Preset, Non Printer | <ul style="list-style-type: none"> C - Printer, Non Preset D - Printer, Preset |
|--|--|

EXAMPLE: Given Model 834 Code 4 Register. To determine the unit features:

- | | | |
|--|---|--|
| <p>1. From "Unit Identification" table (page 14).....</p> <p>we find the key letters:.....</p> <p>Register Unit -- "A".....</p> <p>Preset Unit -- "B".....</p> <p>Print Unit -- "D".....</p> <p>Housing Unit -- "D".....</p> | <p>2. From the key letter description (above) we find the features are:.....</p> <p>Tenths, with reversing spindle, single cam.....</p> <p>Single trip, fork drive.....</p> <p>Zero start printer, face down, tenths.....</p> <p>Printer, Preset.....</p> | <p>For name, number and description of unit parts, refer to:</p> <p>Pages.....4-5</p> <p>Pages.....6-9</p> <p>Pages.....10-12</p> <p>Page.....13</p> |
|--|---|--|

When ordering give: Name and number of each part -- model and code of register -- size and serial number of flowmeter

1310 Emerald Road
Greenwood, SC 29646
USA
Phone: 1.800.833.3357
Fax: 1.864.223.0341

