

P-282
Rev. G
LPG Flowmeter Parts List:
1 1/4" Type 4D LP Gas 1 1/2"
Type 4D LP Gas

RED SEAL MEASUREMENT

Parts List For Neptune LPG Meters



Vapor Release and Strainer

1¼-inch/1½-inch
84982-701

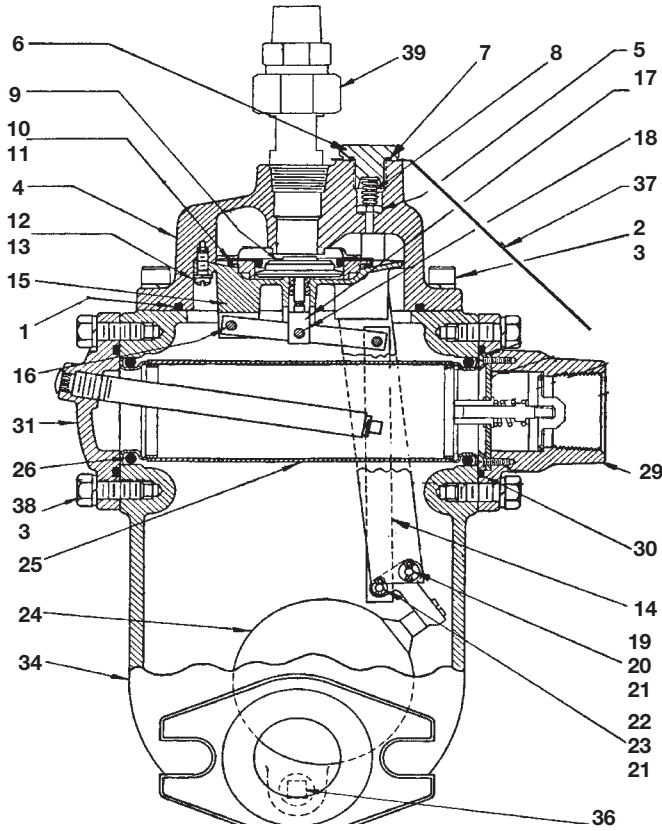

Index	Part	Part Number
		1¼"/1½"
1	Gasket O-ring	100139-022
2	Screw, 3/8-16 x 1, Socket Hd.	8325-014
3	Lockwasher, 3/8 steel	45828-001
	Mounting Cover with Float	83481-701
4	Cover Assembly Vapor Release	400077-701
5	Valve Assembly Bypass	100237-001
6	Screw and Plate Assembly	100333-001
7	O-ring, 1/16 sect x 11/16 ID	100138-006
8	Spring Compression	100024-003
9	Main Valve Complete	89274-006
10	Sleeve, Valve	82446-005
11	Piston, Seal	83179-000
12	Lockwasher, No. 10 steel	41211-000
13	Screw, 10-32 x 5/8 fil hd steel	41221-002
	Lower Valve Housing Complete	86797-001
14	Link Assembly	100334-001
15	Valve Housing with Extensions	82455-000
16	Rivet, Valve Lever	40819-002
17	Stem, Valve	83127-001
18	Pin, Valve Stem	42941-000
19	Pin, Float Lever (long)	40820-003
20	Washer, Float Lever Pin (long)	40491-000
21	Cotter Pin, 1/16 dia x 1/2, brass	41402-000
22	Pin, Float Lever (short)	82633-000
23	Washer, Float Lever Pin (short)	41989-000
24	Float Complete	82476-001
25	Strainer and Gasket Assembly (80-mesh)	101433-704
26	Gasket, Strainer, O-ring	100139-032
29	Inlet Check Valve Complete (soft seat)	84983-704
	Parts Break Down Page 3	—
30	Gasket O-ring	100139-010
31	Strainer Cover (with thermometer well)	83485-702
	Strainer Cover (without thermometer well)	83486-705
32	Washer, Plain, 7/16 steel	—
33	Cap Screw, 7/16-14 x 1-3/8, hex hed steel	—
34	Body, Vapor Release and Strainer	83495-701
35	Lockwasher, 7/16 steel	—
36	Plug, Drain	100075-003
	Bushing, 1-1/2 x 1-1/4 (for 1-1/4" meter)	8384-101
37	Caution Tag	100322-001
38	Cap Screw, 3/8-16 x 1, hex hd steel (without seal hole)	100067-053
	(with seal hole)	100068-027
39	Valve, Vapor Return Check (straight type)	84828-000

Differential Valve

1¼-inch/1½-inch
84985-701

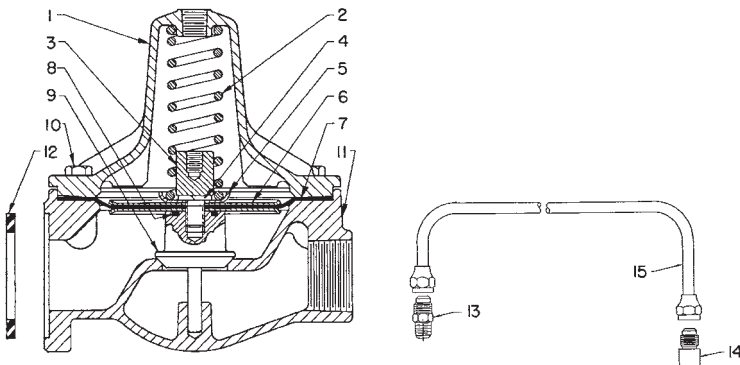

Index	Part	Part Number
		1½"
1	Cover	400000-701
2	Spring, Valve	83775-000
	Diaphragm Complete	1001571
3	Screw, Diaphragm	83774-002
4	Lockwasher, 7/16 steel	41012-002
5	Retainer, Spring	83773-000
6	Retainer, Diaphragm	83772-002
7	Diaphragm	1000624
8	Gasket, O-ring	100139-001
9	Valve, Stem Assembled	83768-002
10	Screw, 3/8 - 16 x 1, hex hd steel	100067-051
	(with seal hole)	100068-050
10A	Lockwasher, 3/8 steel (not shown)	45828-001
11	Body	84986-701
12	Gasket, Flange	82060-000
13	Fitting, Straight, 3/8 flared tube (male half)	84826-000
14	Fitting, Elbow, 3/8 flared tube (male half)	84825-001
15	Tube, Connecting, with Nuts	83937-000
	Tube, Connecting, with Nuts (angle type)	—

* If valve stem (index 9) or screw (index 3) are not as shown in drawing, both parts must be replaced.

1 1/4" / 1 1/2" "Soft Seat" Inlet Check Valve 84983-704

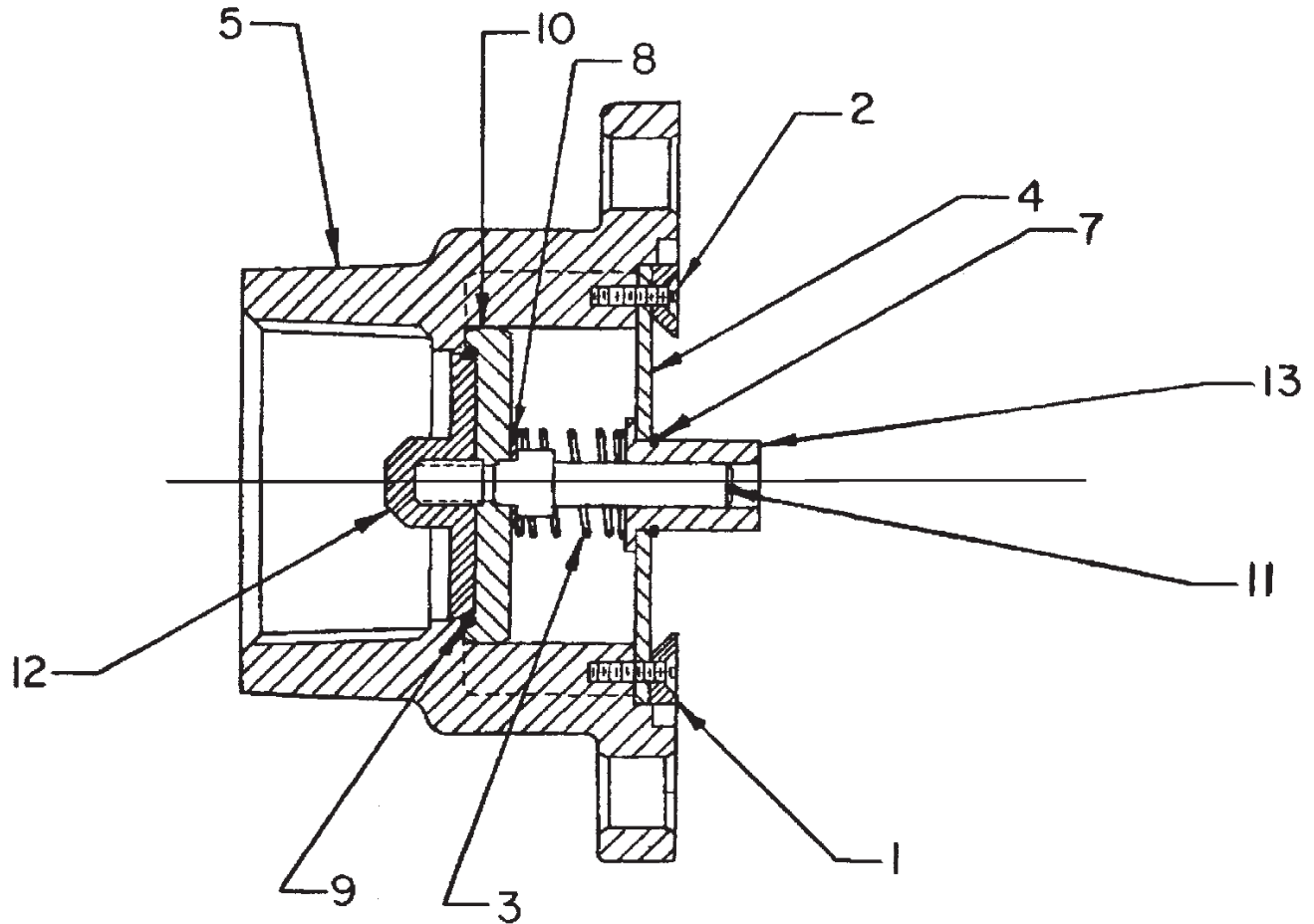

Index	Description	Part Number
1	Ring, Retaining	83441-000
2	Screw	83442-000
3	Spring	83492-000
4	Strap, Inlet Check	83493-003
5	Inlet Flange	84984-005
7	Ring, Retaining, Truarc	86071-000
8	Washer, Lock	41117-000
9	"O" Ring	100146-003
10	Holder, Disk	100423-002
11	Shaft, Inlet Check	100896-001
12	Retainer, Disk	100897-001
13	Bearing	100899-001

Flowmeter without Temperature Compensator

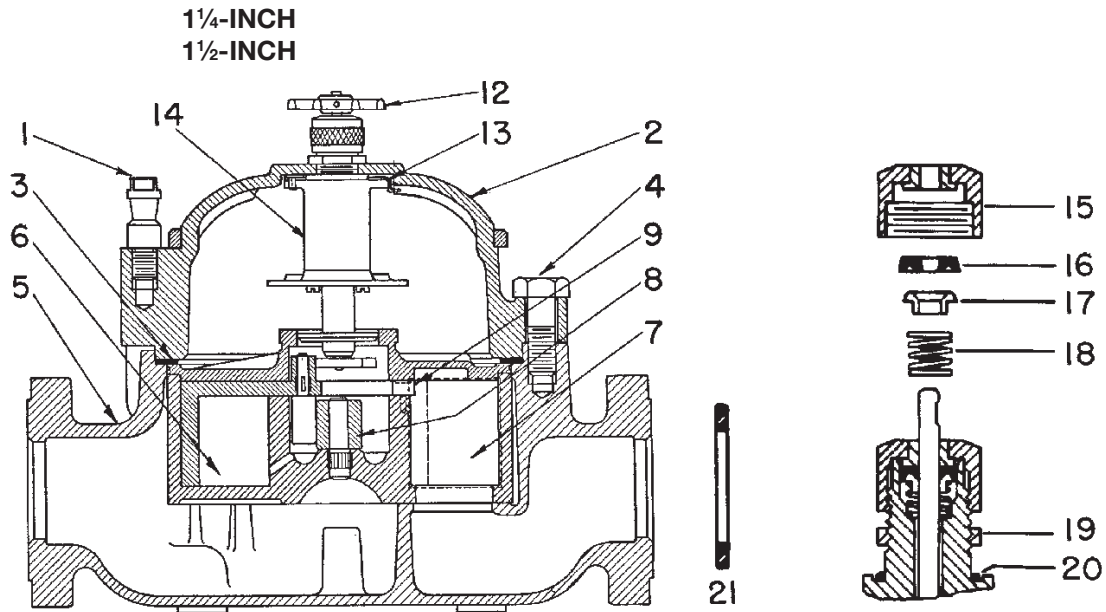

Index	Part	Part Number	
		1 1/4"	1 1/2"
1	Stud Register Mounting	84435-000	84435-000
2	Cover, Main Case	83479-701	83479-701
3	Gasket, Main Case	4862-008	4862-008
4	Screw, Cap, Main Case 7/16 - 14 x 1-3/8	795-003	795-003
	Screw, Cap, Main Case (with seal hole) 7/16 - 14 x 1-3/8	795-011	795-011
4A	Lockwasher, 7/16 Bolt (not shown)	41012-002	41012-002
5	Main Casing with Locating Pin	83477-701	84978-002
6	Measuring Chamber Complete	C43260-101	C83271-101
7	Diaphragm	43271-000	83277-000
8	Roller Control	43275-000	43275-000
9	Pin Seal	42792-000	42792-000
10	Dowel Stud, Seal Pin	—	—
11	Screw, Measuring Chamber	—	—
12	Star Connection with setscrew	82976-001	82976-001
13	Adapter, Gear Train, Non-Swivel	85006-000	85006-000
14	Gear Train Complete		
	9.375 Reduction U.S. Gal	—	84981-000
	11.6 Reduction IMP Gal	—	—
	14.06 Reduction U.S. Gal	83501-000	—
	16.5 Reduction IMP Gal	—	—
	25.4184 Reduction Liters	—	83280-052
	36.41 Reduction Liters	82710-054	—
15	Stuffing Box Nut with Bushing	83536-000	83536-000
16	Seal, U-cup Shaft	100025-002	100025-002
17	Expander Seal	83539-000	83539-000
18	Spring, Stuffing Box	83540-000	83540-000
19	Nut Clamp	34-000	34-000
20	Gasket, O-ring, Gear Train	100138-003	100138-003
21	Gasket, Flange	82060-000	82060-000

Flowmeter with Temperature Compensator

1¼-INCH
1½-INCH

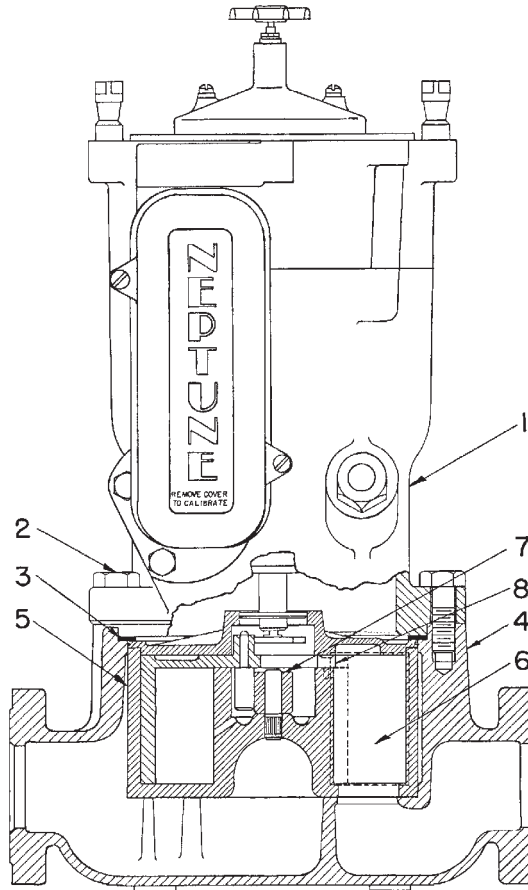

Index	Part	Part Number	
		1¼"	1½"
1	LP-Gas Temperature Compensator	See Note	See Note
2	Cap Screw, Main Case 7/16 - 14 x 1-3/8	795-003	795-003
	Cap Screw, Main Case (with seal hole) 7/16 - 14 x 1-3/8	795-011	795-011
2A	Lockwasher, 7/16 Bolt (not shown)	41012-002	41012-002
3	Gasket	4862-008	4862-008
4	Main Casing with Locating Pin	83477-701	84978-702
5	Measuring Chamber Complete	C43260-101	C83271-101
6	Diaphragm	43271-000	83277-000
7	Roller, Control	43275-000	43275-000
8	Pin Seal	42792-000	42792-000
9	Dowel Stud Seal Pin	—	—
10	Screw, Measuring Chamber	—	—

NOTE: Temperature Compensator parts are shown on pages 6, 7 and 8.

Temperature Compensator, Type 1 Style 2

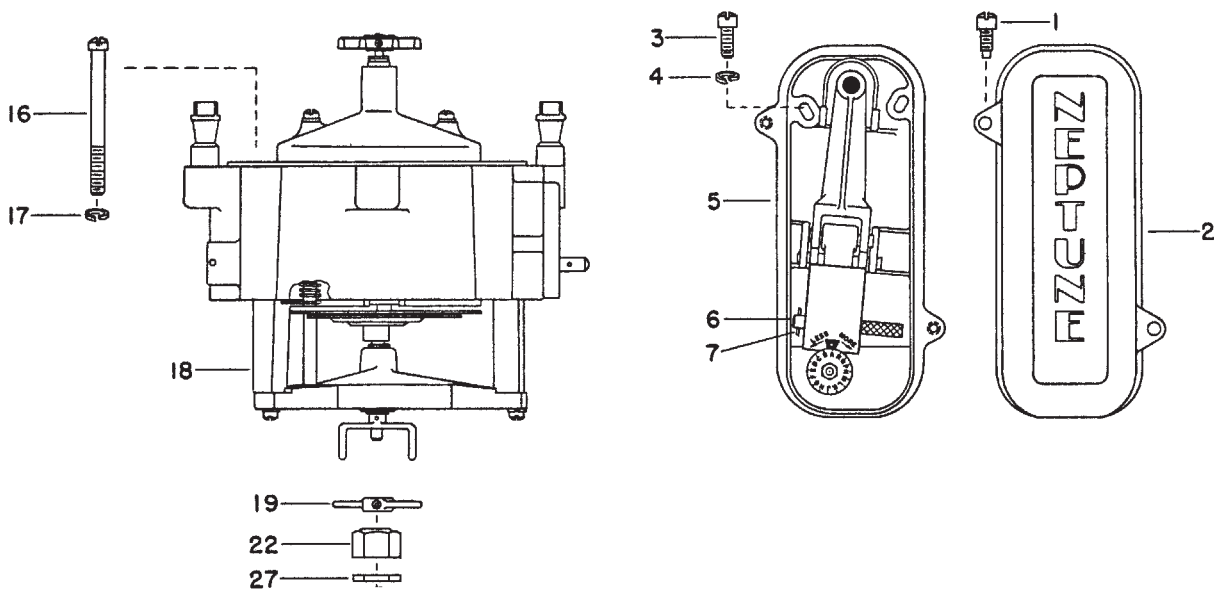

1¼-INCH and 1½-INCH

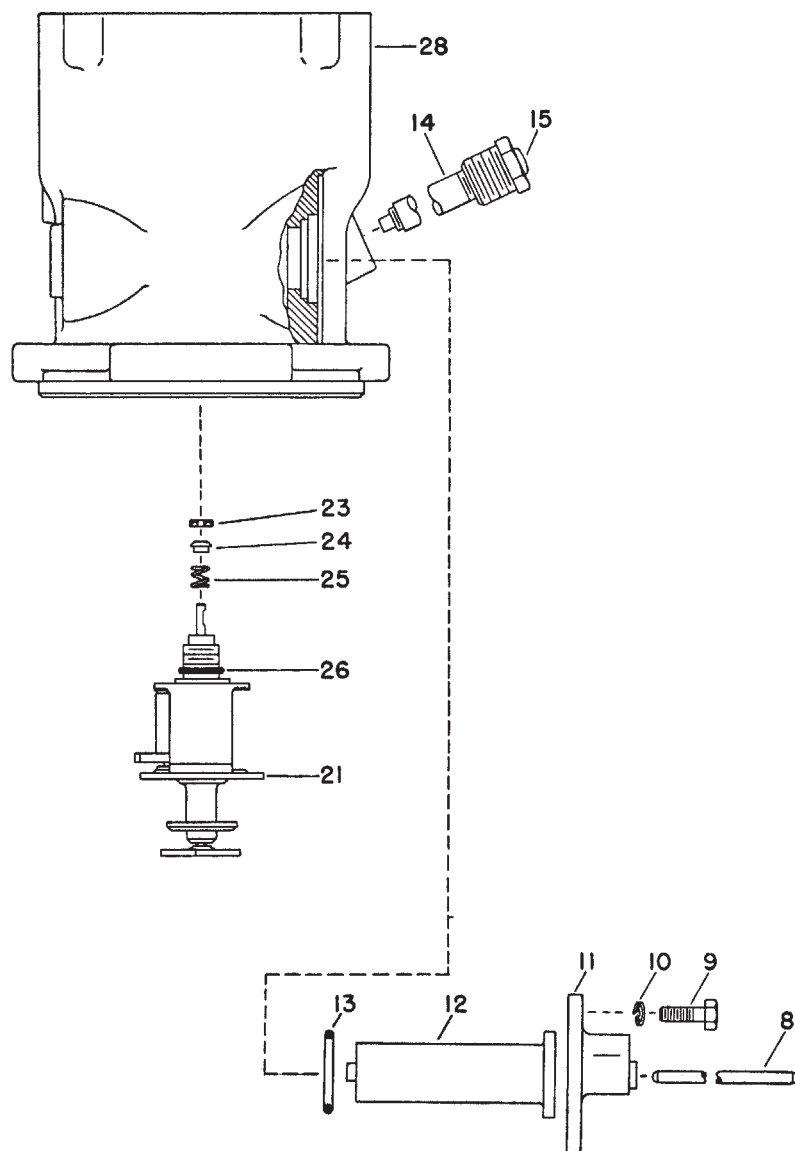

Temperature Compensator, Type 1 Style 2

1¼-INCH — 86600-00X

1½-INCH — 86600-00X

Index	Part	Part Number	
		1¼"	1½"
1	Screw, Cover (10-32 special)	9287-003	9287-003
2	Cover, Lever Arm Mounting Plate	86665-000	86665-000
3	Screw, 10-32 x 5/8, fil hd steel	41221-002	41221-002
4	Lockwasher, No. 10 steel	41211-000	41211-000
5	Mounting Plate and Lever Arm Assembly	86649-003	86649-003
6	Pin, Lever Arm Lock	86661-001	86661-001
7	Cotter Pin, 1/16 dia x 3/8, brass	86973-000	86973-000
8	Pin, Thermostat	86648-000	86648-000
9	Screw, 1/4-20 x 3/4, hex hd steel	83784-000	83784-000
10	Lockwasher, 1/4 steel	41117-000	41117-000
11	Cover, Thermostat	86647-001	86647-001
12	Thermostat (Bellows)	86646-000	86646-000
13	Gasket, O-ring, Thermostat Cover	100139-005	100139-005
14	Thermometer Well Complete	1001906	1001906
15	Cover, Thermometer Well	600443-001	600443-001
16	Screw, 1/4-20 x 2-1/2, fil hd steel	8302-107	8302-107
17	Lockwasher, 1/4 steel, small	88721-000	88721-000
18	Adapter Unit Complete (see page 6)	86602-705	86602-705
19	Driving Arm with Setscrew	82976-001	82976-001
21	Gear Train Complete		
	9.375 Reduction US Gal	—	84981-000
	11.6 Reduction IMP Gal	—	083280-051
	14.06 Reduction US Gal	83501-000	—
	16.5 Reduction IMP Gal	—	—
	25.4181 Reduction Litres	—	83280-052
	36.41 Reduction Litres	82710-054	—
22	Nut and Bushing Assy, Stuffing Box	83536-000	83536-000
23	Seal U-cup Shaft	100025-002	100025-002
24	Expander, Seal	83539-000	83539-000
25	Spring, Stuffing Box	83540-000	83540-000
26	Gasket, O-ring	100138-003	100138-003
27	Nut, Clamp	34-000	34-000
28	Housing, Compensator	86601-701	86601-701

Temperature Compensator Adapter

Part No. 86602-00X

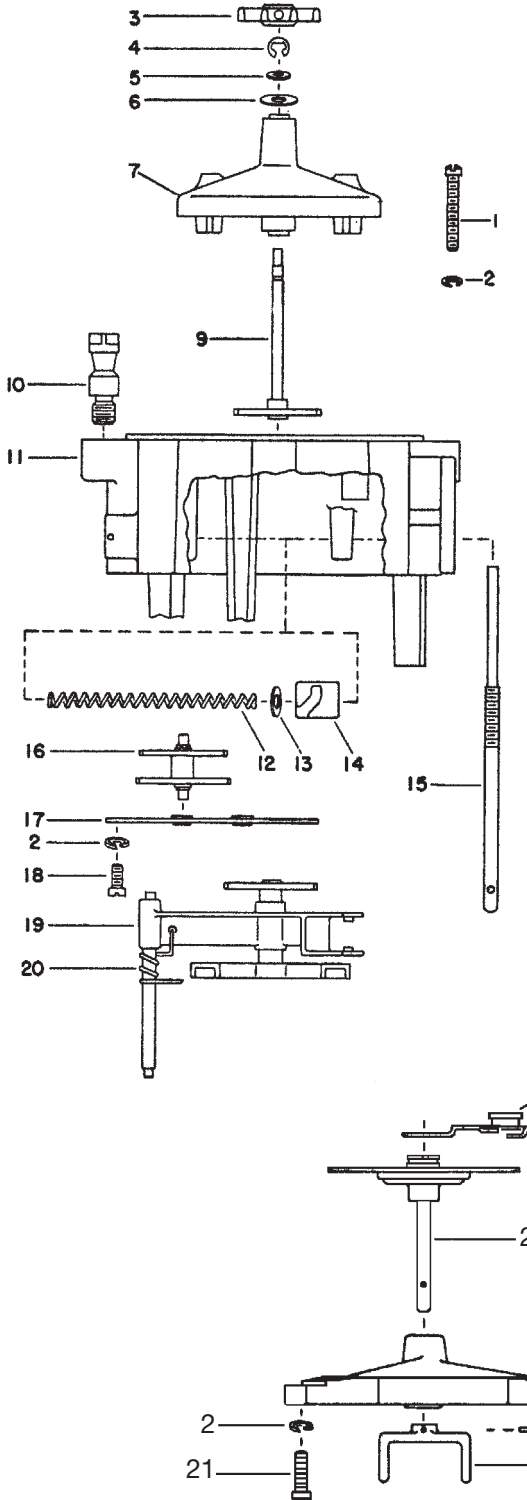

Index	Part	Part Number
1	Screw, 10-32 x 1-1/4, fil hd steel	89073-000
2	Lockwasher, No. 10 steel	41211-000
	Register Drive Bracket Complete	84890-004
3	Star Connection w/Setscrew	82976-001
	Setscrew, 8-32 x 3/16 hollow hd	8538-027
4	Ring, Retaining (Truarc, Type E)	88462-000
5	Washer, Drive Shaft	8571-014
6	Slim, Drive Shaft	46652-001
7	Bracket Assy with Bushings (included in Part # 84890-004)	
9	Gear Complete, Intermediate (41-tooth)	86554-001
10	Stud, Register Mounting	84435-000
11	Adapter with Plug and Bushing	84921-003
12	Spring, Push Rod	84888-000
13	Washer, Spring Retaining	88286-003
14	Swivel Block Assembled	86612-000
15	Push Rod	86611-001
16	Gears & Shaft Assembly (41 and 35 teeth)	84907-001
17	Plate and Bushing Assembly, Idler Gear Retaining	86609-000
18	Screw, 10-32 x 3/8, fil hd steel	88524-000
19	Arm Complete, Offset Spider (with 31-tooth gear)	84910-003
20	Spring, Offset Spider Arm	86645-000
21	Screw, 10-32 x 5/8, fil hd steel	41221-002
22	Arm Assembly, No. 1, 2 reg.	100922-001
22	Arm Assembly, No. 2, 2 reg.	100922-002
23	Spring, Ratchet Pawl	86063-000
24	Ratchet and Shaft, Assembly	100915-002
25	Drive Bracket Assembled (with Bushings)	84914-000
26	Rollpin, 1/16 dia x 3/8, steel	100370-003
27	Drive Fork	84192-006
	Kit — Replacement, Metal w/Plastic	101732-001
	Conversion Kit — Metal to Plastic	101732-001

Drive Bracket Assy. complete with Ratchet and Arms.
Part No. 84913-002

U.S.A./International
1310 Emerald Road
Greenwood, SC 29646-9558
Tel.: Toll-Free (800) 833-3357
(864) 223-1212

Fax:

RED SEAL
MEASUREMENT